

One Door Integrated Distributed Controller

Compact network intelligence at the door

The one door Integrated Distributed Controller (IDC-1) is the smallest controller in Quintron's latest generation of intelligent controller boards. In addition to controlling and monitoring up to 16 sub-controllers (SRI, DRI, ERI, IP, OP or KRI), the IDC-1 also provides the on-board I/O necessary to control one door. Readers, keypads, and readers with integrated keypads that use Wiegand, clock-and-data, or RS-485 signaling are supported.

Inputs and outputs can be assigned to door-related functions or as general purpose I/O. Inputs can be unsupervised or supervised using configurable end-of-line resistance values. Outputs are implemented using Form-C (NO/NC) relays and can be used for fail-safe or fail-secure lock operation. The IDC-1 is capable of storing close to 400,000 card records when using a minimum configuration. A vast array of access control and intrusion detection

scenarios can be implemented using the IDC-1's ability to cause a series of complex actions to occur on a sub-controller based on a time schedule, an event trigger (originating from the same or another sub-controller), or operator control. The IDC-1 connects to its sub-controllers over a two wire RS-485 bus. The IDC-1 is network ready and is managed by a host computer running industry-leading AccessNsite® software.

The host computer downloads credential, command, and configuration data to the IDC-1 and uploads event and status change information for display to an operator. Once the IDC-1 has been configured it can run independently should it lose its connection with the host computer. The IDC-1 will store events in battery-backed RAM when it loses its host connection so that they can be uploaded to the host when the connection is restored.

Features

- Most widely accepted access control hardware due to its reliability and open architecture
- Controls 1 door/ 2 readers
- Manages up to 17 doors when using optional sub-controllers
- Tamper input
- 390,000 card holders (max); 240,000 card holders (typical)
- Mounting bracket has holes that match Single Reader Interface footprint
- Up to 50,000 event buffer
- PIV-II, CAC, TWIC compatible
- AES 128 bit encryption
- Supports up to 8 programmable card formats
- 12v to 24v DC operation or PoE
- Field upgradable firmware
- Mounts in 3-gang junction box
- UL listed 294/1076
- 1 year limited warranty

powered by





IDC-1 Specifications

Power Input

- PoE Power Input 12.95W, compliant to IEEE 802.3af OR 12Vdc +/- 10%, 900mA max.

Power Output

- 12 Vdc @ 650mA including reader and AUX output

Communications

- Host Port: Ethernet 10Base-T/100Base-TX
- Peripheral Port: 2-Wire RS-485 on 1st reader port

Reader Interface

- PoE 12 Vdc +/- 10% or local power supply (12 Vdc) (PTC limited 150mA max)
- One or two wire bi-color LED support
- Buzzer (Only with 'one-wire' LED)
- Two TTL reader ports (one reader port if sub-controllers are connected)

Outputs

- 2 Relays: Form-C, 2A, 30VDC

Inputs

- 4 supervised
- Dedicated tamper monitor

Dimensions

- 5.5"W x 2.75"L x 0.96"H w/o bracket
- 5.5"W x 3.63"L x 1.33"H w/ bracket

Humidity

- 10 to 95% RHNC

Temperature

- 0 to 70°C operating
- 55 to 85°C storage

Certifications

- UL294, UL1076
- CE
- RoHS
- FCC Part 15 Class A
- NIST Certified Encryption



powered by

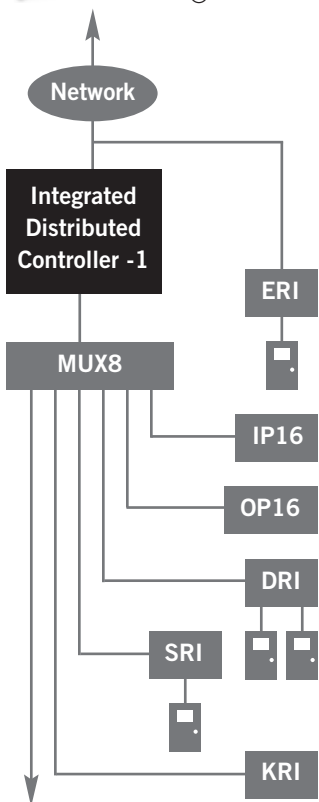

IDC-1 can control up to 16 Sub-Controllers (with restrictions)

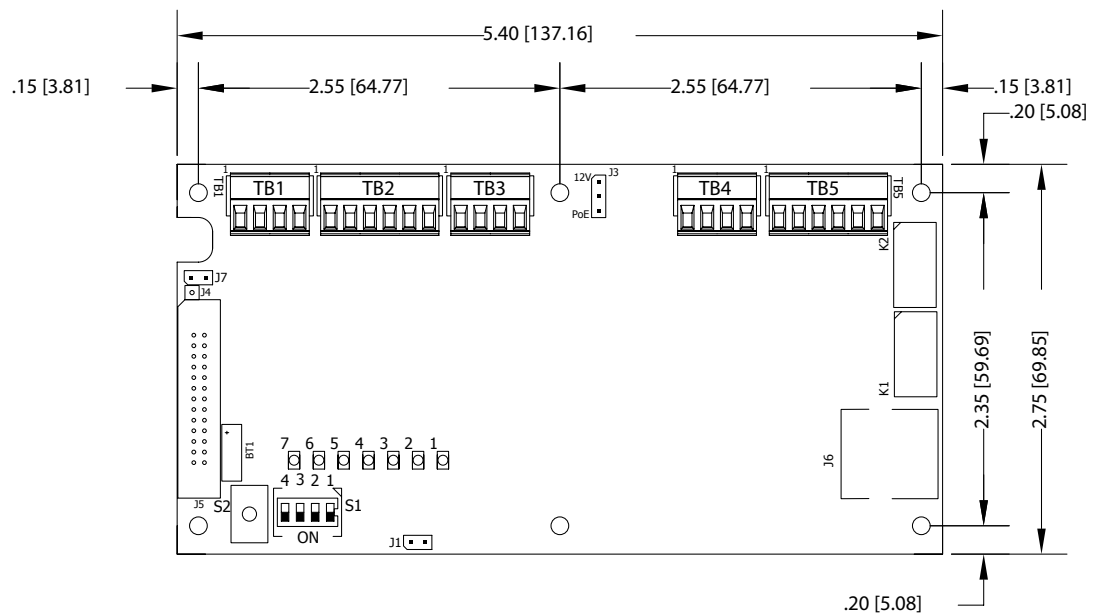

* For a list of pre-configured enclosures, see Quintron's "Enclosures" brochure.