

QUINTRON®

Quintron Systems, Inc.
Recipient of the 2007 North American C4ISR
Product Innovation of the Year Award



“Partnering with clients to create innovative growth strategies”

I. Market Overview

Market Pointer

There are hundreds of Command, Control, Communications, Computers, Intelligence, Surveillance, and Reconnaissance (C4ISR) programs being researched and procured by the U.S. Department of Defense (DoD). Among these are several that are making a key impact on current and future U.S. forces operational success and several that may be considered of marginal relevance to counter-terror and counter-insurgency warfare.

Implication to Market Participants

Some contractors that provide C4ISR equipment and services to the U.S. DoD are beginning to reflect in their strategic market plans the trend away from immature high technology programs to those that utilize more proven Commercial-Off-The-Shelf (COTS) based tools with open architectures and industry standards. The need to reequip and "reset" U.S. ground forces and the looming budget prioritization process has become a major news item.

Competitive Landscape

Participants in the U.S. DoD market range in size from large multi-national corporations to sole proprietorships. There are three basic types of firms involved. 1) Lead Systems Integrators (LSIs) are large firms typically divided by business unit responsibilities. The firms then combine resources for large projects and team with specialized segments from other LSIs, mid tier, or small companies. 2) Mid-tier defense firms have grown in importance due to their understanding of and responsiveness in providing solutions for troops in the field. They have the technological expertise that LSIs often lack and the ability to seek out and utilize the niche and up-and-coming technologies found in the commercial sectors. They are often the focus of merger activity, both acquiring small companies and are they themselves targets of firms seeking a quick entry into a particular U.S. DoD market segment. Mid-tier firms are especially attractive to foreign investors. 3) Small Companies have many innovative ideas and often team with larger firms to gain access to DoD prime contracts on programs of record. Several of these "small" firms actually have very large commercial markets, but their participation in the DoD market is just beginning. They are of particular interest as they have the latest in commercial standards experience and engineering depth. The DoD hopes to continue to leverage established and cutting edge commercially successful technologies with military potential in order to field new capabilities quicker and cheaper.

Addressing this Particular Market

Communications equipment for ground forces is the most pressing need for the U.S. C4ISR community today and for the next few years. There is a gap between current equipment that has been worn out by hard use over the last few years and a delay in fielding next generation software defined radios that have been developed at a slower pace and at more expense than was originally planned. The rapid growth and success of commercial wireless networks has also had an unexpectedly important impact on U.S. tactical networks concept of operations.

II. Award Categories & Relevance

U.S. DoD business opportunities are based upon the budget cycle, procurement programs, and acquisition process that typically run 5-7 years. Each military service, DoD agency, functional, and regional combatant commander maintains its own purchasing authority to meet service unique and joint requirements. DoD programs of record are acquisition requirements that constitute an "approved need" according to the DoD Directives and are listed in the Future Years Defense Program (FYDP) funded by Congress. Acquisition programs are a directed, funded effort that provides a new, improved,

or continuing material, weapon, or information system or service capability. Commercial firms bid to fulfill the requirements of these programs through DoD issued Requests for Proposals (RFPs) and/or Requests for Information (RFI). Firms are also encouraged to submit proposals independently if they have an idea or technology they think can meet DoD goals. The U.S. DoD market is dominated by a few prime contractors who then subcontract needed technologies, services, and components. About 65.0 percent of total contracts value is awarded to LSIs, 15.0 percent to mid tier firms, and 20.0 percent to small service and technology companies.

III. 2007 North American C4ISR Product Innovation of the Year Award

Award Description

The Frost & Sullivan Award for Product Innovation of the Year is presented each year to the company that has demonstrated excellence in new products and technologies within their industry. The recipient company has shown innovation by launching a broad line of emerging products and technologies.

Research Methodology

To choose a recipient of this Award, the analyst team tracks all new product launches, research and development spending, products in development, and new product features and modifications. This is accomplished through interviews with the market participants and extensive secondary and technology research. All new product launches and new products in development in each company are compared and evaluated based on degree of innovation and customer satisfaction. Companies are then ranked by number of new product launches and new products in development.

Measurement Criteria

In addition to the methodology described above, there are specific criteria used to determine final competitor rankings in this industry. The recipient of this Award has excelled based on one or more of the following criteria:

- Significance of new product(s) in their industry
- Competitive advantage of new product(s) in their industry
- Product innovation in terms of unique or revolutionary technology
- Product acceptance in the marketplace
- New product value-added services provided to customers
- Number of competitors with similar product(s)

Award Recipient: Quintron Systems, Inc.



Quintron's mission control, command center, interoperability, and mobile/tactical communications products provide innovative solutions to U.S. DoD interoperability and legacy upgrade requirements. Quintron's DICES IV Secure Audio Enhancement system provides user access to all audio sources through a single headset, integrating legacy and digital secure telephone connections, personal computer audio, and other Internet Protocol based devices.

Quintron Systems is an employee owned interoperable voice systems and physical access control/intrusion detection systems engineering and manufacturing firm. Headquartered in Santa Maria, California, for over 36 years, the company has provided cost effective solutions to government and industry in support of mission critical communications and security requirements.

The Quintron DICES IV product technology was adapted to provide a generational upgrade for the existing Vandenberg AFB Range Status Alert system under a subcontract to ITT Corporation for the Spacelift Range System Contract (SLRSC). Quintron is providing a complete technology upgrade within current net-centric operating environments, while maintaining existing legacy interfaces and operating procedures with minimal additional training requirements. Launch controllers utilize dual touch screen console units, one screen for status input, and the second screen to provide status display from other operators. Central redundant servers provide system connectivity via standard Ethernet-IP and configuration management for all operator displays. Separate I/O servers accept IP commands and convert them into legacy narrow band audio signals for status communications between the Western Range Operations Control Center (WROCC) and the Vandenberg AFB launch pads.

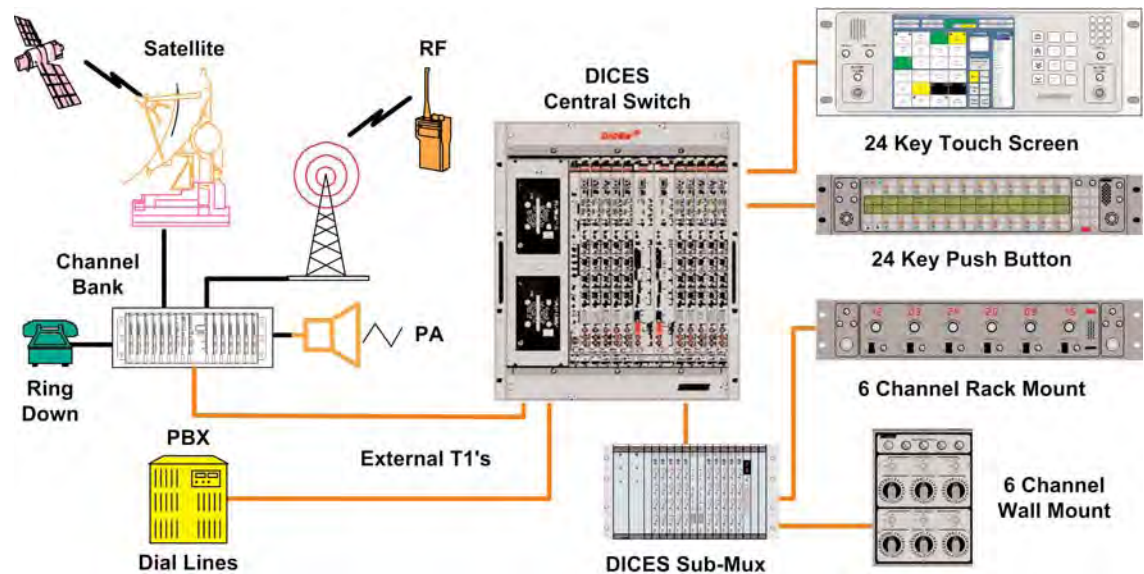

DICES IV System mission and command control features include:

- Integration of all audio into single, multi-access user device (several types)
- Dual independent audio channels for user flexibility on talk and monitor channels
- Priority override at key level supports Multi-Level Secure (MLS) audio access
- Redundant central system servers provide full data and control security
- Distributed processor cards on all central units with redundant links to servers
- Admin Client is JAVA-based for platform and operating system independence
- Local, Remote, and Global System Admin Clients supported
- Admin and Keyset User Password log-in with full activity recording
- All system data connections are standard IP LAN / WAN

Quintron's U.S. DoD market product innovation leadership is demonstrated by their innovative engineering services that provide off-the-shelf or custom solutions to help solve difficult DoD challenges. Quintron adapted the existing DICES IV product architecture into a completely different space launch control application to provide an upgrade from a 1960's technology to a Client-Server IP based Status Alert system. Quintron has helped their industry partners and the DoD save time and money by utilizing open architecture information technology to meet immediate operational needs. Thus, Quintron is selected for the 2007 Frost & Sullivan C4ISR Product Innovation of the Year Award.